

NOTES

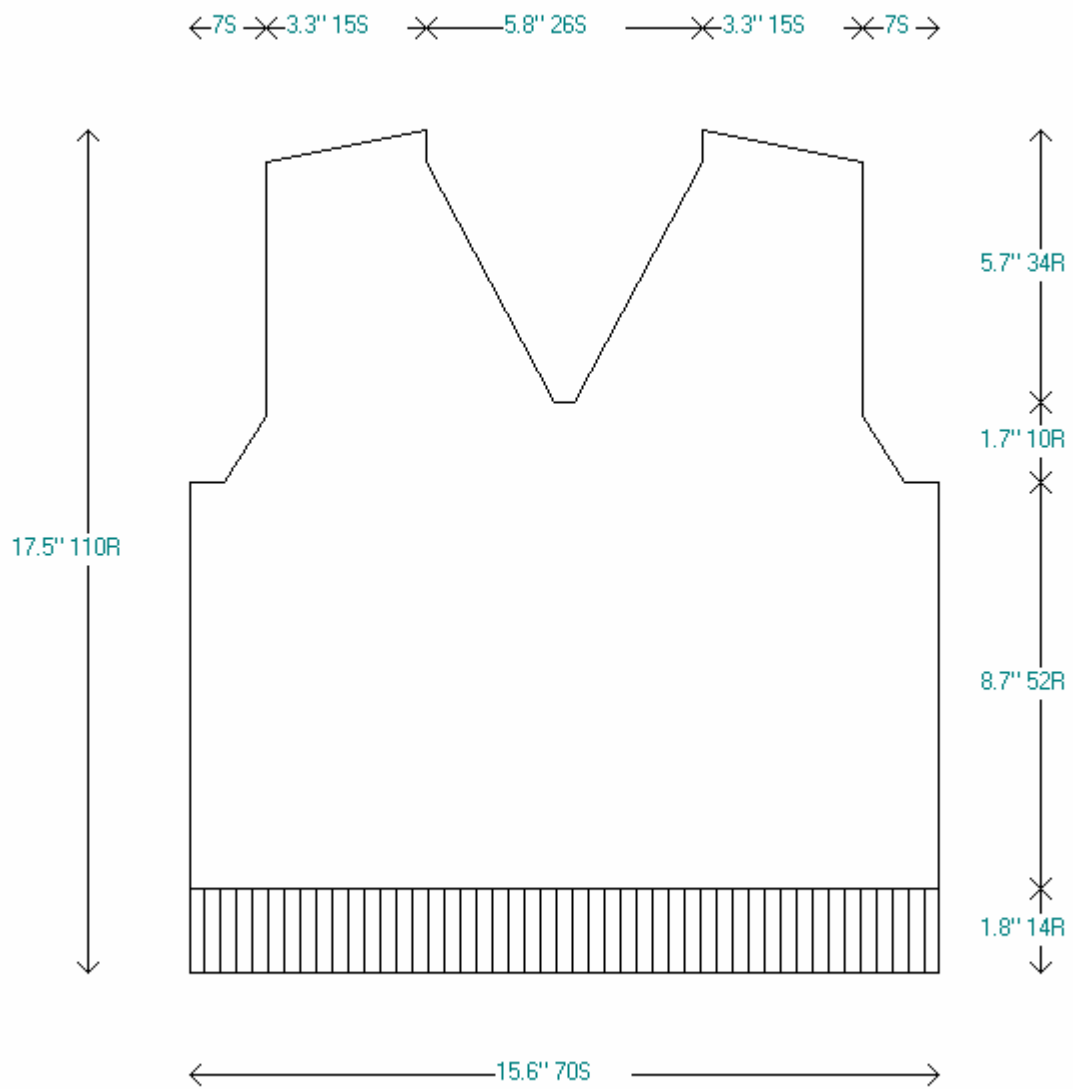

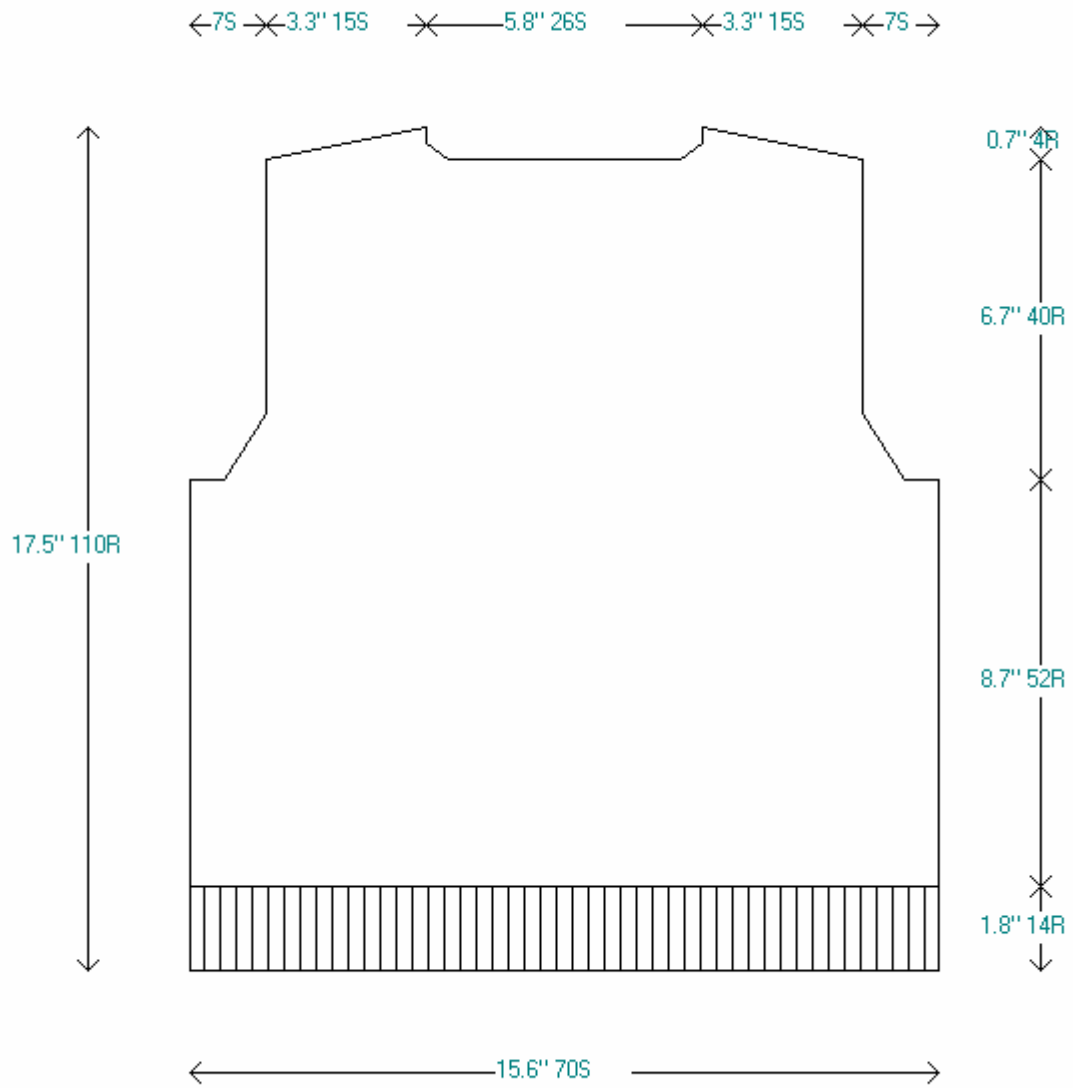

Stripe pattern according to your school house colors.

Size of stripe if sequence is 1/1/1 rows = .5"

Size of stripe if sequence is 1/2/1 rows = .656"

In order to obtain an accurate gauge, please knit a tension swatch to determine if you need to use smaller or larger needles.

Hobbie's is not responsible for sizing problems. Knitting a swatch should establish an accurate stitch gauge but if in doubt as to the accuracy of the row gauge, follow the measurements of the diagram and adjust your rows accordingly.

Pattern designed and edited by: Hobbie's House Designs

with KNITWARE DESIGN (Version 2.40.3) from Morningdew Consulting Services Ltd

ph: (250)652-4097 fax: (250)652-5285 web: www.knitware.ca email: info@knitware.ca

FRONT:

- 1-2 Follow steps 1 and 2 as for back.
3. Armhole. Dec for armhole at both ends, as for back. Continue until armhole measures 1.7 ins (10 rows), with 56 sts remaining.
4. Divide for neck. Work both sides at the same time. Work 27 sts. With a second ball of yarn, cast off center 2 sts, and work remaining 27 sts.
5. Shape neck. Dec 1 st at neck edge of next row, then every 2nd row 5 times, then every 3rd row 6 times, until 15 sts remain.
6. Work even until armhole measures 6.7 ins (40 rows).
7. Shoulder shaping. Cast off as for back.

SLEEVES:

1. Cast on 33 sts on size 6 needles. Work in K1P1 ribbing for 1.5 ins. Inc 3 sts evenly across the row to 36 sts total.
2. Change to size 8 needles and Stocking Stitch.
3. Inc 1 st at each end of every 12th row 5 times to 46 sts (60 rows total, excluding hem).
4. Work even until sleeve measures 12.0 ins (72 rows), excluding hem.
5. Shape cap. Cast off 3 sts at beg of next two rows. Dec 1 st at each end of every 2nd row 4 times, then dec 1 st at each end of every 3rd row 6 times, then dec 1 st at each end of every 2nd row 3 times. Cast off remaining 14 sts loosely.

SHOULDER SEAMS:

1. Sew fronts to back along shoulder seams.

V FRONT NECK SINGLE BAND COLLAR:

Knit on size 6 needles. Worked in 2 pieces.

1. With right side of work facing, pick up and work (starting at bottom of front neck) 27 sts from right front neck edge, 2 sts from right back neck edge and 11 sts from back neck holder to center. Total 40 sts.
2. Work 1.0 ins (8 rows) in K1P1 ribbing.
3. Cast off loosely.
4. Work the left side the same way as the right, picking up the back neck sts first.

FINISHING:

1. Sew sleeve top to armhole, easing to fit. Sew side and sleeve seams using invisible seam. Sew any remaining seams.
2. Darn/weave/sew in all loose ends.

AMOUNT OF YARN REQUIRED TO MAKE GARMENT:

THIS IS A ROUGH ESTIMATE ONLY. We suggest you purchase 1-2 extra skeins in the same dye lot.

Amount needed:

8.0 ounces for body and sleeves
1.1 ounces for ribbing and/or hems
0.3 ounce for neckband

9.4 Ounces TOTAL

NOTES:

US Needle size 8 Metric 5 mm

Rib US Needle 6-7

85 Gr. - 3 oz / 197 Yards

V-Neck Sweater Pattern for Children

This pattern is for a regular length, straight pullover sweater with ribbing at lower edges and sleeve cuffs. It features moderately tapered, full-length set-in sleeves with ribbed cuffs. V front neck with a shallow back neck for a better fit. Neck is trimmed with a ribbed single band.

Size: Standard Child 28 [Children's Size 10]

YARN DESCRIPTION:

Wool-Ease by Lion Brand; Main Color #153 or #152;
80% Acrylic - 20% Wool; Machine Wash and Dry 80* F.

GAUGE:

Gauge (Stocking Stitch over 4 in = 10 cm): 18.0 sts by 24.0 rows.
Body on US# 8 needles
Ribbing on US# 6 needles

FINISHED sweater measurements in inches: ... with average fit.

- Total finished chest: 30.1"
- Width of ribbed hem: 30.0"
- Total body length: 17.5" [adjust length by adding or subtracting 6 rows/inch during Step 2 of back or front]
- Total armhole: 13.0"[6.5" each front and back]
- Top Neck Opening: 5.8
- Hem Width: 6.9
- Point of V-neck front: 0.5"
- Width of sleeve top: 10.1"
- V-neck depth: 5.5"
- Back neck width: 4.9"
- Back neck depth: 0.4"
- Back shoulder width: 12.1"
- Total sleeve length: 13.5"
- Width of sleeve at cuff: 7.6"
- Cuff depth: 1.5"
- Neckband depth: 1.0"
- Rib depth: 1.8"

BACK:

1. Cast on 70 sts on size 6 needles. Work in K1P1 ribbing for 1.8 ins.
2. Change to size 8 needles and Stocking Stitch. Work even until piece measures 8.7 ins (52 rows – adjust length here), excluding hem.
3. Armhole shaping. Cast off 3 sts at beginning of next 2 rows. Dec 1 st at each end of every alternate row for 8 rows until 56 sts remaining. Continue until armhole measures 6.7 ins (40 rows), with 56 sts remaining.
4. Shape neck. Work both sides at the same time. Work 17 sts. Slip the next 22 sts to a holder. With a second ball of yarn, work remaining 17 sts. Dec 1 st at neck edge every row twice, until 15 sts remain.
5. At the same time, when armhole measures 6.7 ins (row 40), start shoulder shaping.
6. Shoulder shaping. Cast off 7 sts at armhole edge, then cast off 8 sts at armhole edge.